

Slewing Drive Performance Parameters

Rated Output Speed	<2.5rpm	
Output Torque (Max.)	15 kN.m	11064 lbf.ft
Tilting Moment (Max.)	203 kN.m	149x10 <sup>3</sup> lbf.ft
Holding Torque	105.8 kN.m	78x10 <sup>3</sup> lbf.ft
Static Axial Rating (Max.)	1598 kN	360x10 <sup>3</sup> lbf
Static Radial Rating (Max.)	640 kN	144x10 <sup>3</sup> lbf
Gear Rating	125:1	
Precision	≤0.15°	

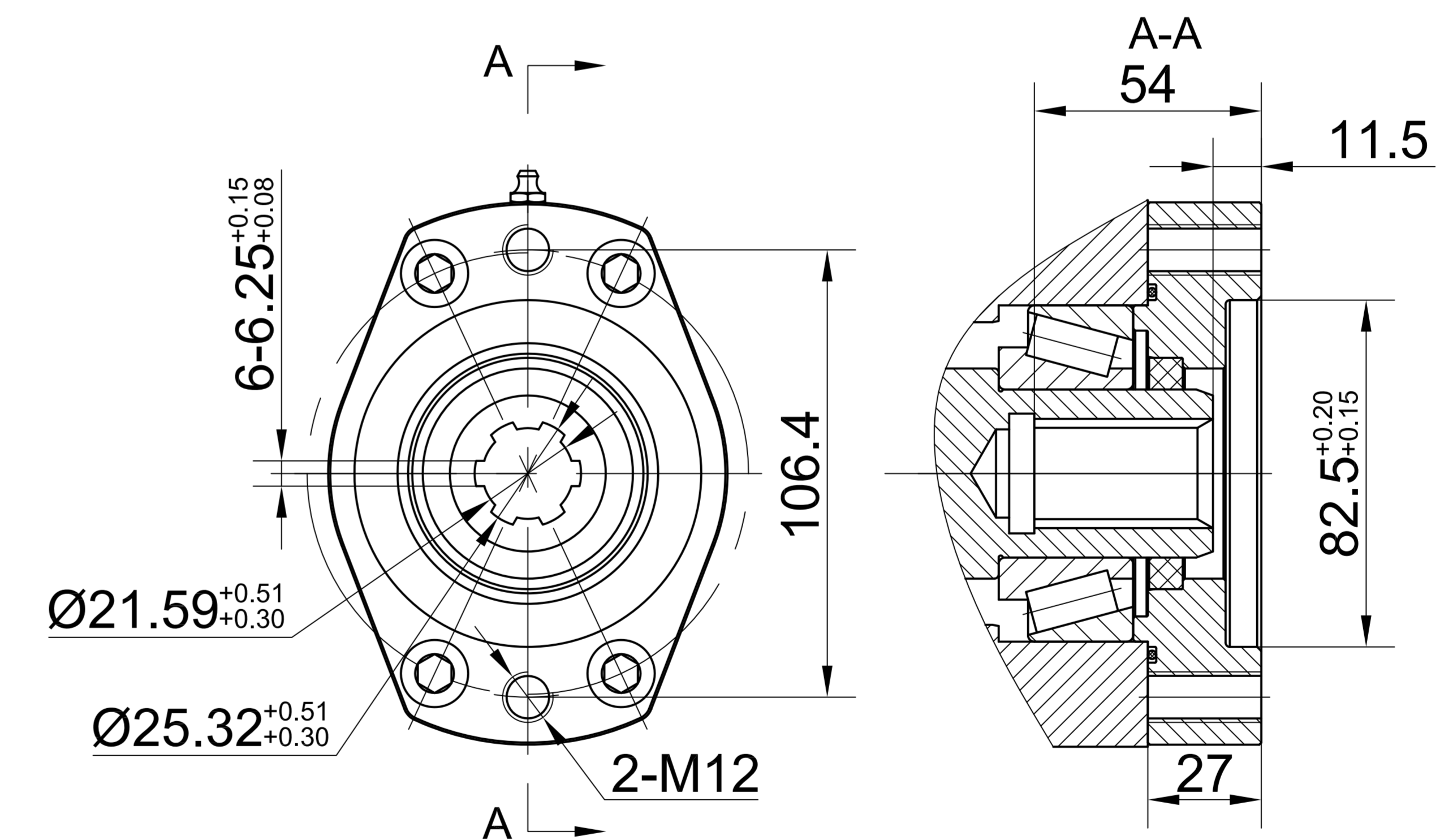
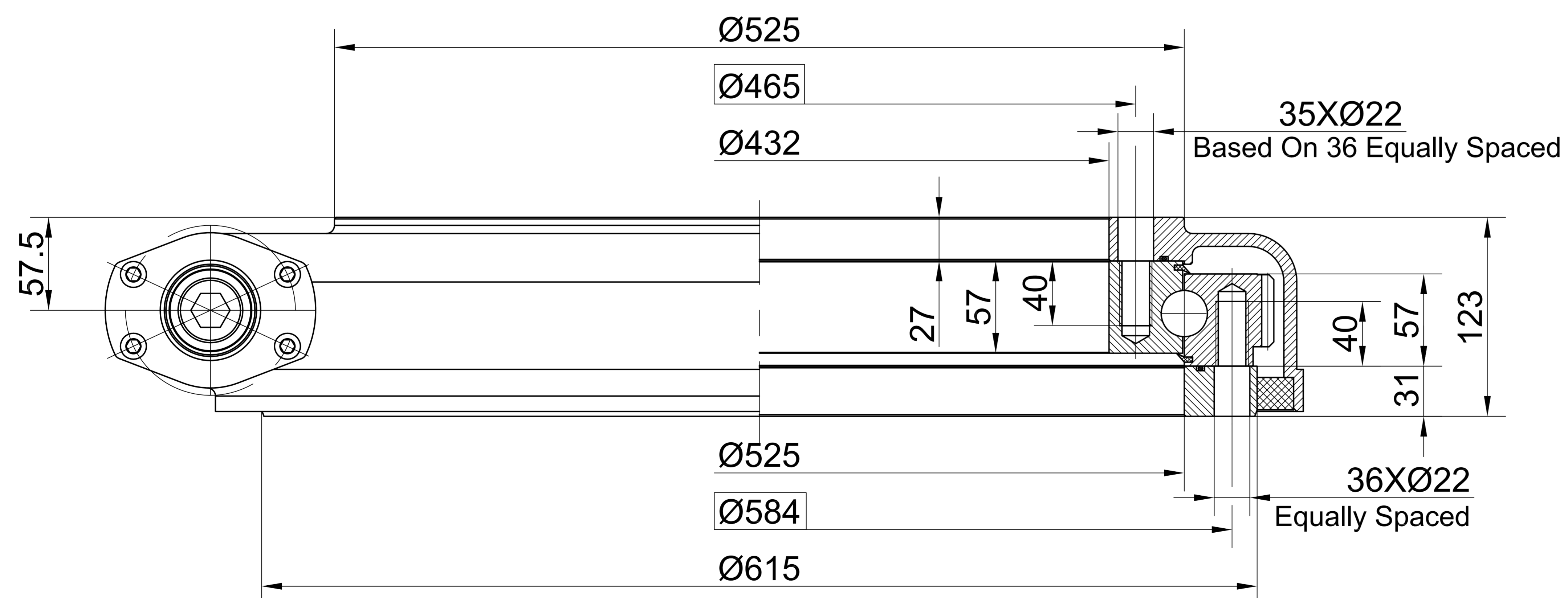
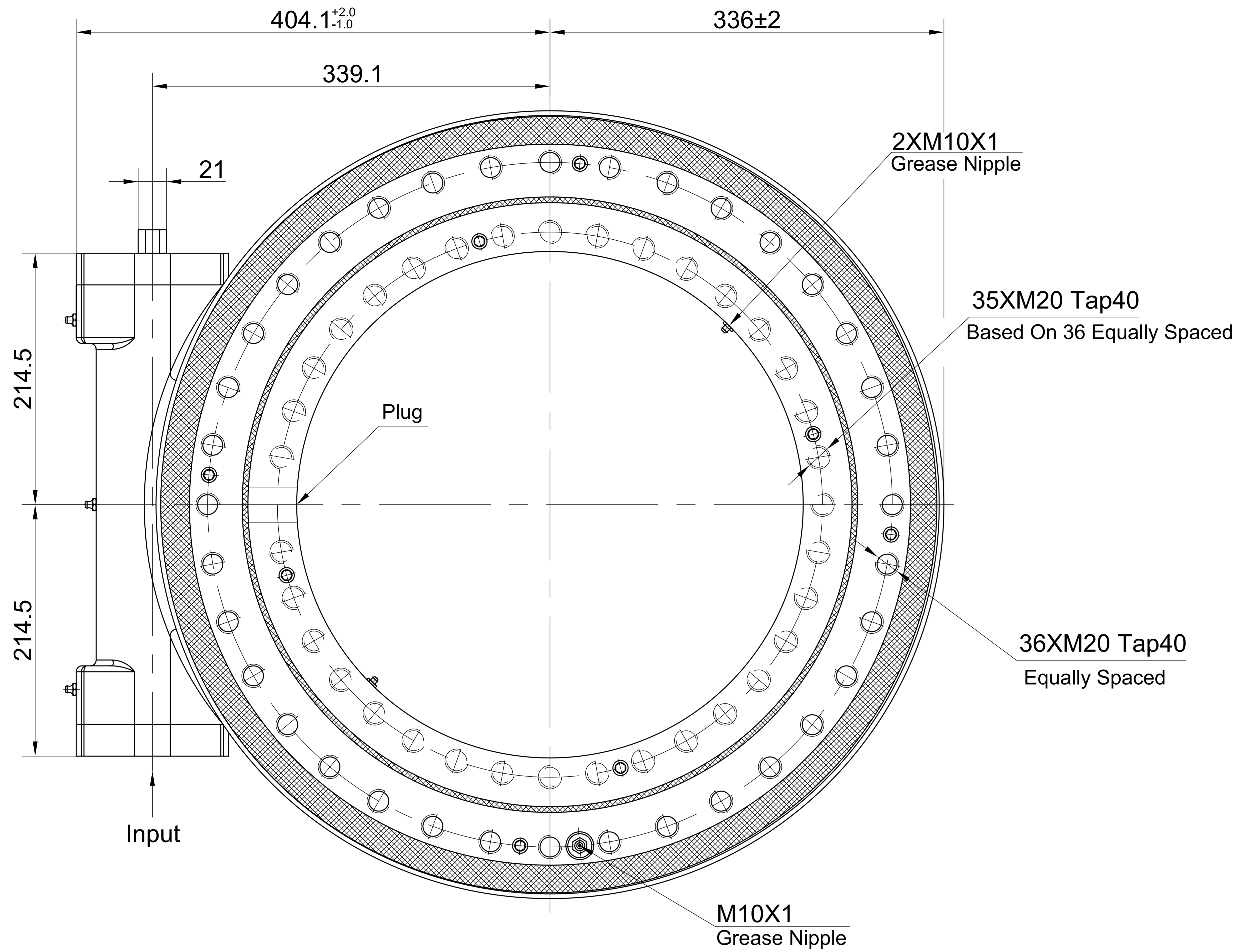
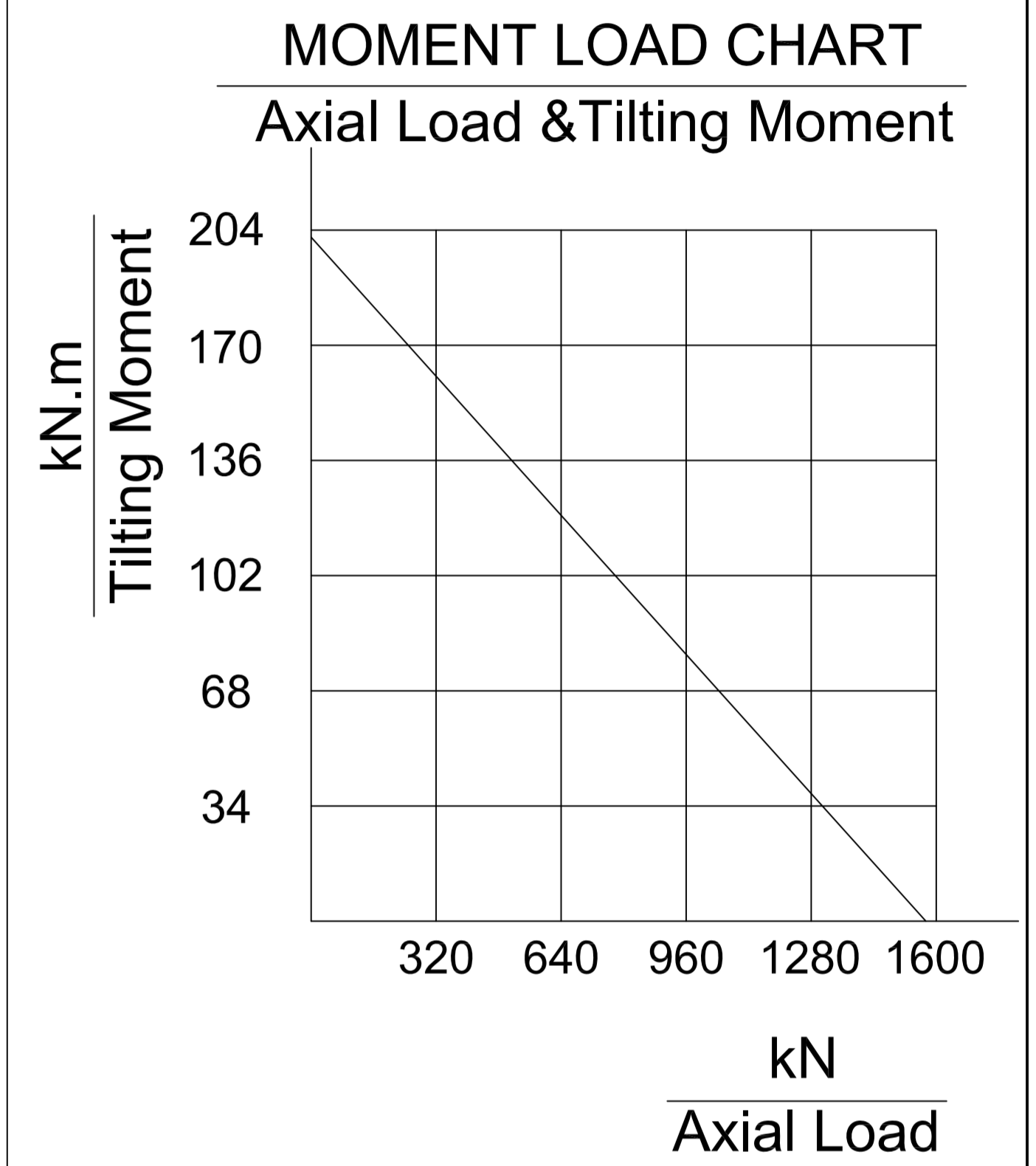

REV.	Date	Reviser	Description		
Designed By	2016-4-22	HXL			
Checked By	2016-4-22	PYN			
Approve By	2016-4-22	CMP			
<small>The information contained in the document is property of SunSlew. SunSlew reserve changes of manufacture without previous advice and duty of communication. It is not allowable any copy or reproduction of this certificated copy with the original not under control.</small>			WEIGHT	SCALE	<b>Slewing Drive</b>
			118.54	1:5	
SYMBOLS ISO			SIZE	A3	<b>SDL21-125B-BRH</b>
			SHEET	1	
					REV A