



Operating Worldwide for our Customers

Quick Axis Change (QAC) Head line

Options

A-axis

- + **With one motor**
Torque S1: 550 Nm
Maximum torque: 1,100 Nm
- + **Pneumatic clamping**
with safety function
Clamping torque: 2,160 Nm
- + **Accuracy of measuring system: ± 2''**
- + **Leakage monitoring**

C-axis size 1+2

- + **Pneumatic clamping**
with safety function
Clamping torque / size 1: 9,900 Nm
Clamping torque / size 2: 15,120 Nm*
- + **Measuring system**
with enhanced accuracy for all standard CNCs
- + **Horizontal or vertical installation position**

Motor spindles

Model	S1			S6 / 40% [DC: 2 min.]		Tool interface	Bearing lubrication
	Max. speed	Torque [Nm]	Power [kW]	Torque [Nm]	Power [kW]		
MT100S	20,000	85	20	115	20	HSK 63	Oil-air lubrication
MT100S	12,500	85	20	115	20	HSK 63	Permanent grease lubrication
MT100L	20,000	130	50	200	50	HSK 63	Oil-air lubrication
MT100L	12,500	130	50	200	50	HSK 63	Permanent grease lubrication
MT100H	16,000	145	60	175	60	HSK 100	Oil-air lubrication
MT100H	12,500	200	54	235	54	HSK 100	Oil-air lubrication
PC100	30,000	60	100**	80	120**	HSK 63	Oil-air lubrication

Availability and other tool interfaces possible on request. * planned (preliminary values) **converter dependent

www.precise-rotation.ru

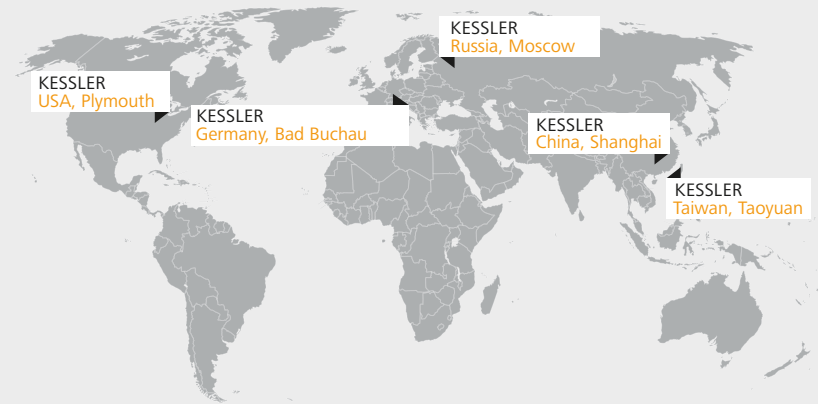

Germany

Franz Kessler GmbH
Franz-Kessler-Straße 2
88422 Bad Buchau, Deutschland
Tel.: +49 7582 809 - 0
Fax: +49 7582 809 - 170
E-Mail: info@kessler-group.biz

Taiwan

KESSLER Taiwan Co., Ltd.
2F, No.315, Sec 1
Minsheng N. Rd
Guishan Township
Taoyuan County 333
Taiwan (R.O.C.)
Tel.: +88 63 326 2256
Fax: +88 63 355 5014
E-Mail: info.tw@kessler-group.biz

KESSLER energy GmbH
Franz-Kessler-Straße 2
88422 Bad Buchau, Deutschland
Tel.: +49 7582 809 - 0
Fax: +49 7582 809 - 170
E-Mail: info.energy@kessler-group.biz

China

**KESSLER (Shanghai)
Spindle Service Co., Ltd.**
Rm. 201 Building #12
No.318 Yuanshan Rd
Minhang District
201108 Shanghai, China
Tel.: +86 21 6489 7034
Fax: +86 21 6489 7134
E-Mail: info.cn@kessler-group.biz

USA

KESSLER USA Inc.
44099 Plymouth Oaks Blvd.
Plymouth, MI 48170, USA
Tel.: +1 734 404 0152
Fax: +1 734 404 0153
E-Mail: info.usa@kessler-group.biz

Russia

KESSLER East Ltd.
Dorogobuzhskaja str., 14, bld. 6
121354, Moscow, Russland
Tel.: +7 495 204 2450
E-Mail: info.ru@kessler-group.biz



SPINDLE TECHNOLOGY | SYSTEM TECHNOLOGY | DRIVE TECHNOLOGY | SERVICE SOLUTIONS

SPINDLE TECHNOLOGY | SYSTEM TECHNOLOGY | DRIVE TECHNOLOGY | SERVICE SOLUTIONS

www.kessler-group.biz

www.kessler-group.biz

SMALL 2AH (QAC)

Uncompromised rough-machining or finishing on a machine

A-axis (tilting axis)

- Speed: 100 rpm
- Torque S1: 1,100 Nm
- Maximum torque: 2,200 Nm
- Clamping: hydraulic
- Clamping torque: 4,000 Nm
- Clamping with safety function
- Tilting angle: $\pm 110^\circ$
- Measuring system: absolute
- Accuracy of measuring system: $\pm 5''$

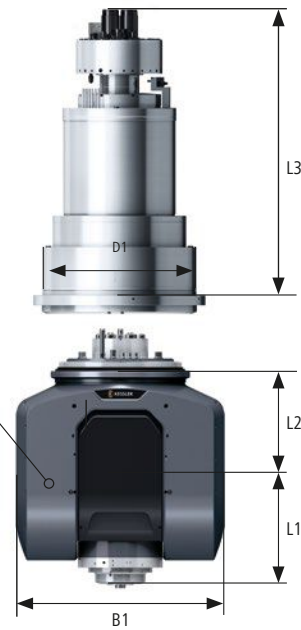

Dimensions (mm) - changing interface - size 1

Fitting diameter of C-axis	D1	540
Vector length	L1	260 (HSK63) / 280 (HSK100)
Projection length of A-axis	L2	410
Fitting depth of C-axis	L3	1,005
Width of A-axis	B1	625
Depth of A-axis		420
Collision circle C-axis		670
Gross weight	kg	1,025

Availability and measuring „size 2“ on request

Quick Axis Change (QAC)

C-axis with changing interface – size 1

- Fitting \varnothing : 540 mm

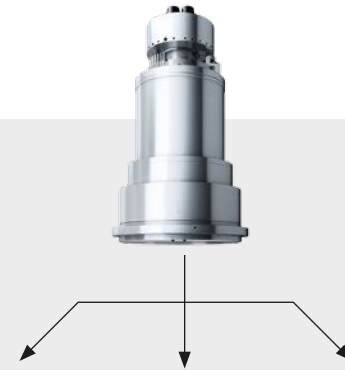

MINI 2AH ⓘ

SMALL 2AH

MEDIUM 2AH ⓘ

C-axis (turning axis)

- Torque S1: 2,700 Nm
- Maximum torque: 5,700 Nm
- Clamping: hydraulic
- Clamping torque: 12,500 Nm

- Speed: 100 rpm
- Tilting angle: $\pm 360^\circ$
- Measuring system: absolute
- Accuracy of measuring system: $\pm 5''$

C-axis with changing interface – size 2

- Fitting \varnothing : 540 mm



MINI 2AH ⓘ

SMALL 2AH

MEDIUM 2AH ⓘ

LARGE 2AH ⓘ

C-axis (turning axis)

- Torque S1: 4,266 Nm*
- Maximum torque: 8,800 Nm*
- Clamping: hydraulic
- Clamping torque: 18,000 Nm*

- Speed: 100 rpm
- Tilting angle: $\pm 360^\circ$
- Measuring system: absolute
- Accuracy of measuring system: $\pm 5''$

* planned (preliminary values)

ⓘ Availability on request