

# Table line Rotary tables / Rotary tilt tables

Top positioning accuracy for ultra-precision 5-axis machining

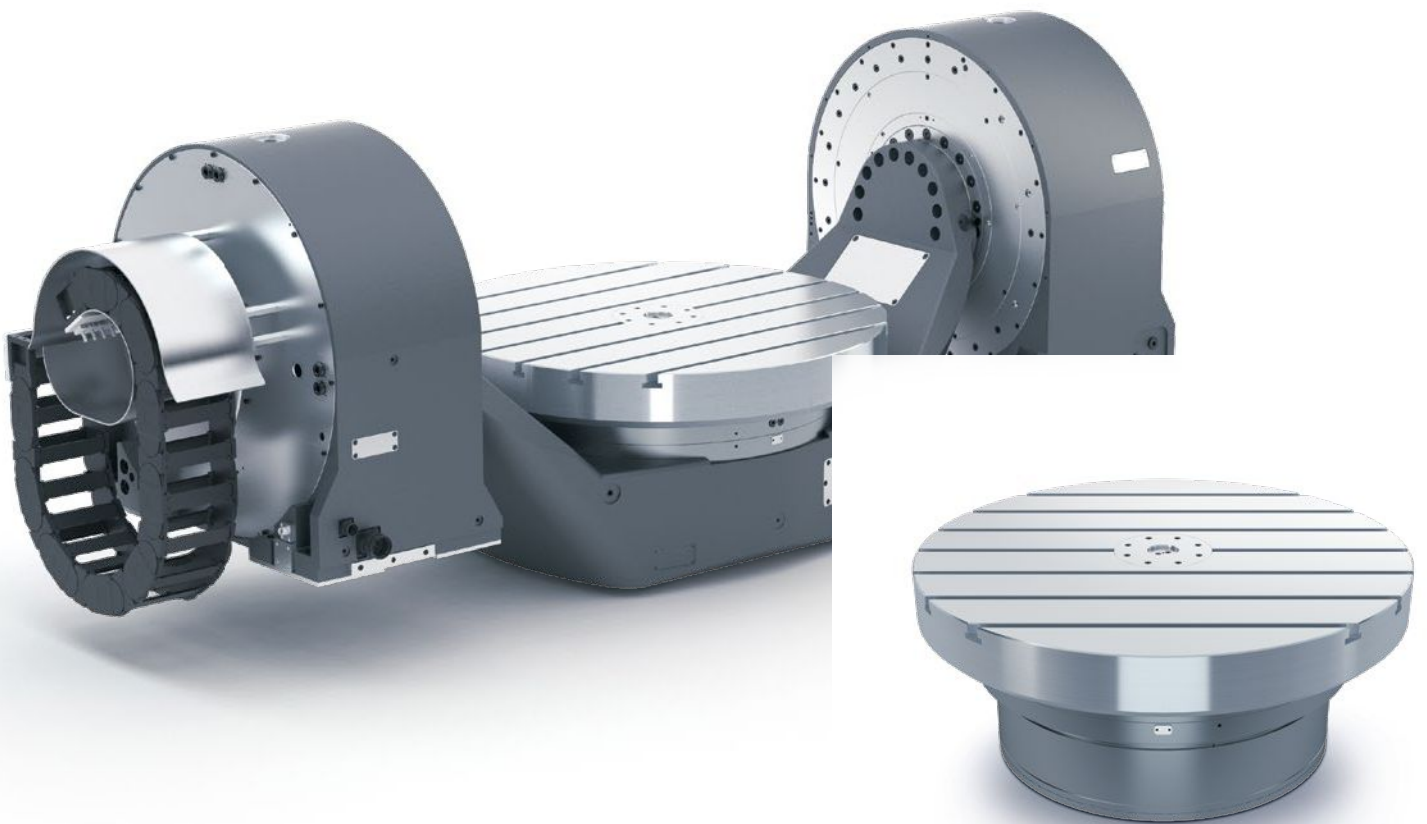



# Rotary tables and rotary tilt tables with KESSLER motors

Stay a revolution ahead with the KESSLER Table *line*

The KESSLER Table *line* includes single-axis rotary tables and dual-axis rotary tilt tables.

It incorporates the renowned KESSLER know-how for superior quality and innovative technology. The individual components form a modular system which can be configured to suit your specific requirements. Allow us to build the ideal system for your application environment.

Heavy workpieces can be quickly positioned and secured. High positioning accuracy ensures precise results for 5-axis machining. KESSLER's very latest torque motor generation, the ultra-flexible rotary and rotary tilt tables feature high acceleration and tilting speeds for maximum productivity. High-speed rotary tables can also be used for turning operations.

## End-to-end precision from the components to the on-site service

Founded in 1923 by Franz Kessler, the company has developed to become the leading supplier of motor spindles as well as directly driven 2-axis heads and rotary tilt tables for the machine tool industry. KESSLER proudly counts many major companies from the mechanical engineering sector amongst its long-standing customers.

With the expertise of more than 90 years, KESSLER is continuously further developing and optimizing its products. The KESSLER product portfolio serves a wide range of sectors, procedures and applications. Close cooperation with our customers remains our key focus. The extensive product portfolio, ranging from hightech spindles, 2-axis heads, rotary and rotary tilt tables to motors and direct drive systems, enables KESSLER to realize customized solutions with speed and flexibility.

Service is a matter of trust. Rely on us as your trusted service partner: KESSLER has an established global network of technology and service centres.



# Experts for simultaneous processing

The right table for every workpiece: [www.precise-rotation.ru](http://www.precise-rotation.ru)

Modular table system from MINI to LARGE

## KESSLER Table line

MINI 2AT 400/600	SMALL 2AT 500/630	MEDIUM 2AT 630/800	LARGE 2AT 800/1,000
			<p>n request</p>
MINI 1AT 400/600 (MT)	SMALL 1AT 500/630 (MT)	MEDIUM 1AT 630/800 (MT)	LARGE 1AT 800/1,000 (MT)

Individually customized to your requirements:

- **2 drive axes for 3 sizes:**  
 The rotary tilt tables MINI 2AT one-sided and SMALL 2AT both-sided, plus SMALL 2AT one-sided and MEDIUM 2AT both-sided each having the same drive components.
- **Table cartridge:**  
 use as high-speed rotary version for milling-turning operations or with lower speed for just milling and drilling operations.

1 AT = 1-axis table      MT = mill turn  
 2 AT = 2-axis table      P = positioning

# All advantages at a glance

- **5-axis simultaneous processing with direct drive**
- **Precision stops and defined tilting axis height**  
Simple adjustment in the machine tool
- **Modular design**  
for individual configuration
- **Highly flexible and suitable** for a wide variety of applications, easy to change table plate [www.precise-rotation.ru](http://www.precise-rotation.ru)
- **Precise machining**  
results due to high positioning accuracy
- **Very maintenance friendly**  
Worn parts can be easily replaced on site

- **Various table plates**  
available – individual shapes can be defined as required

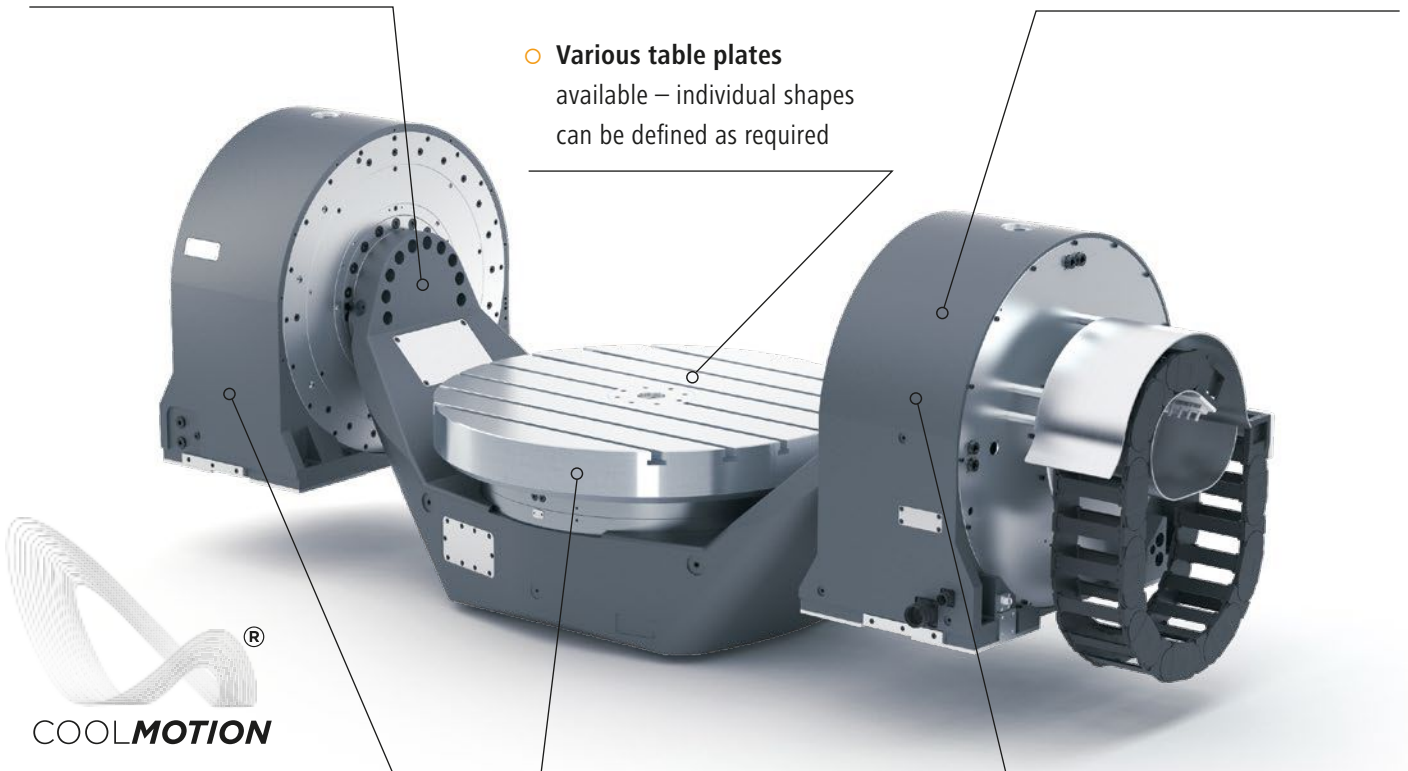



- **More dynamic** due to powerful **KESSLER COOLMOTION®** motors
- **Turning operation option**  
with high-speed rotary tables
- **High productivity** due to fast acceleration and tilting speed
- **Extremely robust designed**  
with high rigidity
- **Cable carrier**  
on the left or right

## HIGH QUALITY

MADE IN GERMANY

## MINI 1AT





	Milling table cartridge MINI 1AT	Milling-turning table cartridge MINI 1AT MT	Positioning table MINI 1AT P
Table plate diameter (mm)	400 - 600	400 - 600	500
Maximum speed (rpm)	200	1,500	25
Maximum vertical workpiece weight (kg) 	1,000	700	1,000
Maximum horizontal workpiece weight (kg) 	500	350	-
Total height (mm)	300	300	215
Torque S1 (Nm)	400	450	265/530
Maximum torque (Nm)	800	750	800
Clamping	Hydraulic / Pneumatic table	Hydraulic	Hydraulic
Clamping torque (Nm)	2,000	2,000	2,040
Measuring system	Absolute	Absolute	Absolute
Accuracy of measuring system (")	± 5	± 5	± 7.5
Cooling	Water	Water	Convection / Water

Positioning tables cannot be used in rotary tilt tables!





## SMALL 1AT

	Milling table cartridge SMALL 1AT	Milling-turning table cartridge SMALL 1AT MT	Positioning table SMALL 1AT P
Table plate diameter (mm)	500 - 630	500 - 630	630
Maximum speed (rpm)	100	1,200	25
Maximum vertical workpiece weight (kg) 	2,000	1,000	2,000
Maximum horizontal workpiece weight (kg) 	850	500	-
Total height (mm)	355	355	300
Torque S1 (Nm)	1,040	1,250	430/860
Maximum torque (Nm)	2,080	1,875	1,290
Clamping	Hydraulic / Pneumatic table	Hydraulic	Hydraulic
Clamping torque (Nm)	3,200	3,200	4,500
Measuring system	Absolute	Absolute	Absolute
Accuracy of measuring system (")	± 5	± 5	± 6
Cooling	Water	Water	Convection / Water

Positioning tables cannot be used in rotary tilt tables!

## MEDIUM 1AT





	Milling table cartridge MEDIUM 1AT	Milling-turning table cartridge MEDIUM 1AT MT	Positioning table MEDIUM 1AT P
Table plate diameter (mm)	630 - 800	630 - 800	800
Maximum speed (rpm)	100	1,000	25
Maximum vertical workpiece weight (kg) 	3,000	1,700	3,000
Maximum horizontal workpiece weight (kg) 	1,200	850	-
Total height (mm)	338	353	300
Torque S1 (Nm)	1,850	2,100	750/1,500
Maximum torque (Nm)	3,700	3,100	2,240
Clamping	Hydraulic / Pneumatic table		Hydraulic
Clamping torque (Nm)	4,000	4,000	7,000
Measuring system	Absolute		Absolute
Accuracy of measuring system (")	± 5		± 5
Cooling	Water	Water	Convection / Water

Positioning tables cannot be used in rotary tilt tables!

[www.precise-rotation.ru](http://www.precise-rotation.ru)

## LARGE 1AT



	Milling table cartridge LARGE 1AT	Milling-turning table cartridge LARGE 1AT MT	Positioning table LARGE 1AT P
Table plate diameter (mm)	-	1,000	1,000
Maximum speed (rpm)	-	800	25
Maximum vertical workpiece weight (kg) 	-	3,000	4,000
Maximum horizontal workpiece weight (kg) 	-	1,500	-
Total height (mm)	-	494	300
Torque S1 (Nm)	-	2,000	970/1,940
Maximum torque (Nm)	-	3,000	2,720
Clamping	-	Hydraulic	Hydraulic
Clamping torque (Nm)	-	7,500	9,000
Measuring system	-	Incremental	Incremental
Accuracy of measuring system (")	-	± 5	± 5
Cooling	-	Water	Convection / Water

Positioning tables cannot be used in rotary tilt tables!

### Modular extensions (MINI to LARGE 1AT)

- + Pressure monitoring
- + Rotary union
- + Prepared for balancing monitoring system
- + Pallet changer
- + Pneumatic clamping

# MINI 2AT

## A-axis (tilting axis)

- Torque S1: 1,040 Nm
- Maximum torque: 2,080 Nm
- Maximum speed: 100 rpm
- Clamping: hydraulic / pneumatic table
- Clamping torque: 3,200 Nm
- Tilting angle:  $\pm 120^\circ$
- Measuring system: absolute
- Accuracy of measuring system:  $\pm 5''$

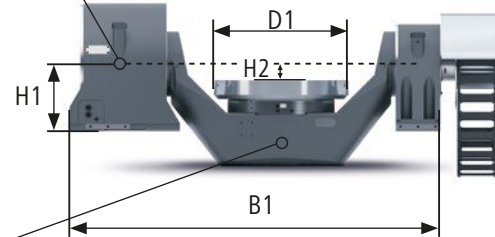

## C-axis (turning axis)

- Torque S1: 400 Nm
- Maximum torque: 800 Nm
- Maximum speed: 200 rpm
- Clamping: hydraulic / pneumatic table
- Clamping torque: 2,000 Nm
- Measuring system: absolute
- Accuracy of measuring system:  $\pm 5''$

Dimensions (mm)		
Table plate diameter	D1	400 - 600
Distance A-axis to table surface	H2	60
Total width	B1	1,377
Height of A-axis to mounting surface	H1	250
Workpiece - maximum $\varnothing$	mm	630
Maximum workpiece height	mm	315
Maximum workpiece weight	kg	500
Total weight	kg	950



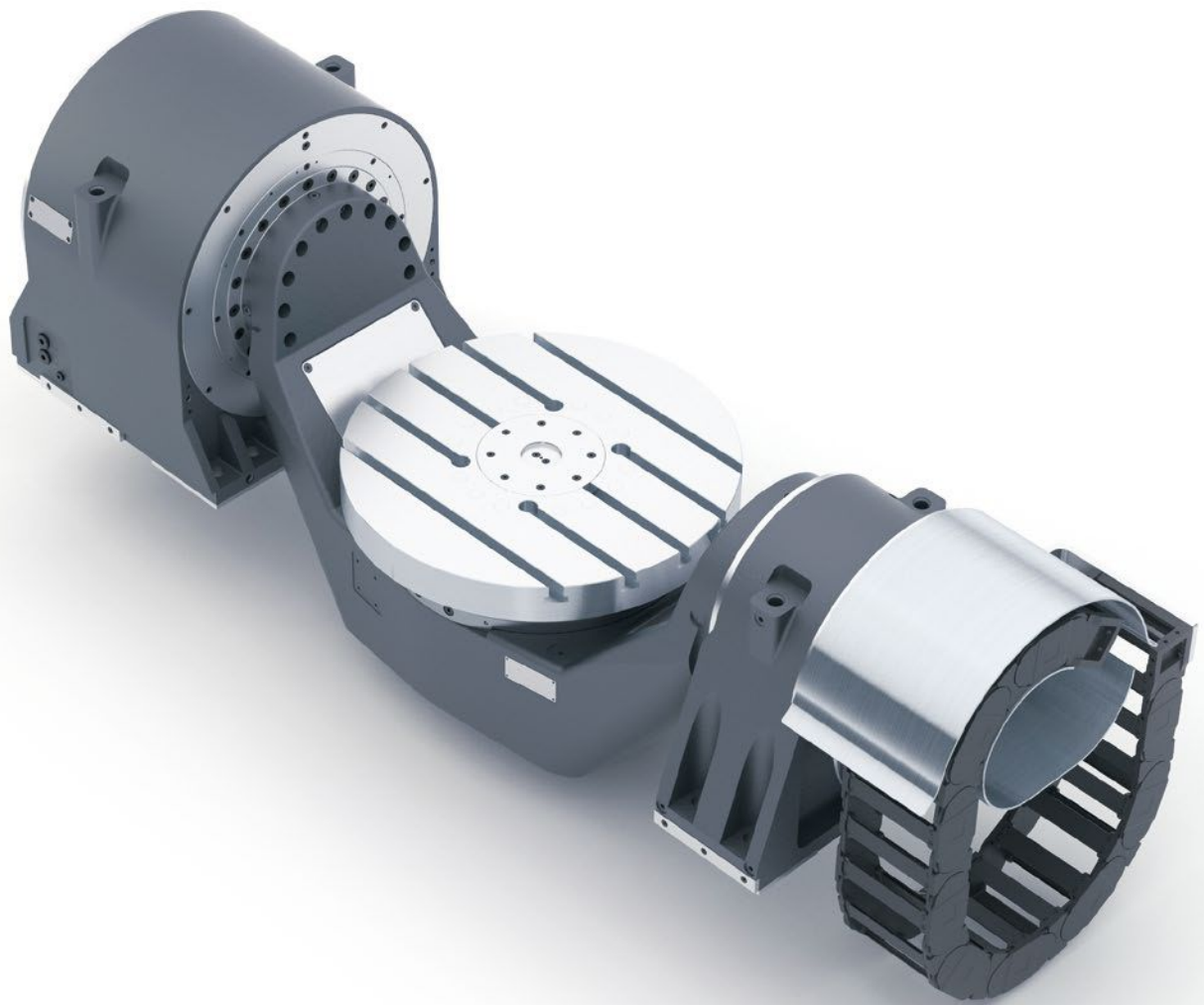

### Modular extensions available

#### A-axis

- + **Pneumatic clamping**
- + **Leakage monitoring**
- + **Pressure monitoring**
- + **Cable carrier**
- + **Measuring system**  
with enhanced accuracy for all  
standard control systems

#### C-axis

- + **High-speed rotary**  
(maximum speed: 1,500 rpm)
- + **Pneumatic clamping**
- + **Leakage monitoring**
- + **Pressure monitoring**
- + **4 and 8 channel rotary union**
- + **Pallet clamping system**
- + **Measuring system**  
with enhanced accuracy for all  
standard control systems

# SMALL 2AT

## A-axis (tilting axis) One-sided drive

- Torque S1: 1,850 Nm
- Maximum torque: 3,700 Nm
- Maximum speed: 100 rpm
- Clamping: hydraulic / pneumatic table
- Clamping torque: 4,000 Nm
- Tilting angle:  $\pm 120^\circ$
- Measuring system: absolute
- Accuracy of measuring system:  $\pm 5''$

## A-axis (tilting axis) Driven on both sides

- Torque S1: 2 x 1,040 Nm
- Maximum torque: 2 x 2,080 Nm
- Maximum speed: 100 rpm
- Clamping: hydraulic / pneumatic table
- Clamping torque: 2 x 3,200 Nm
- Tilting angle:  $\pm 120^\circ$
- Measuring system: absolute
- Accuracy of measuring system:  $\pm 5''$

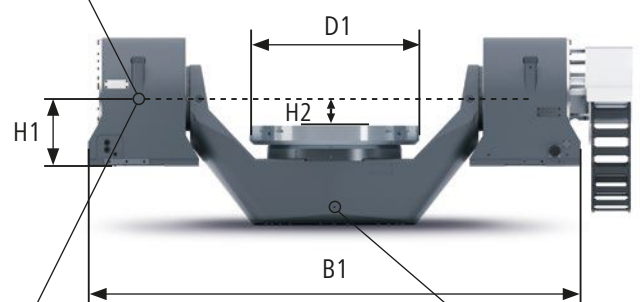

## C-axis (turning axis)

- Torque S1: 1,040 Nm
- Maximum torque: 2,080 Nm
- Maximum speed: 100 rpm
- Clamping: hydraulic / pneumatic table
- Clamping torque: 3,200 Nm
- Measuring system: absolute
- Accuracy of measuring system:  $\pm 5''$

Dimensions (mm)		Version driven on one side	Version driven on both sides
Table plate diameter	D1	500 - 630	500 - 630
Distance A-axis to table surface	H2	100	100
Total width	B1	1,625	1,820
Height of A-axis to mounting surface	H1	325 / 250	250
Workpiece - maximum $\varnothing$	mm	800	800
Maximum workpiece height	mm	400	400
Maximum workpiece weight	kg	850	850
Total weight	kg	1,320	1,400

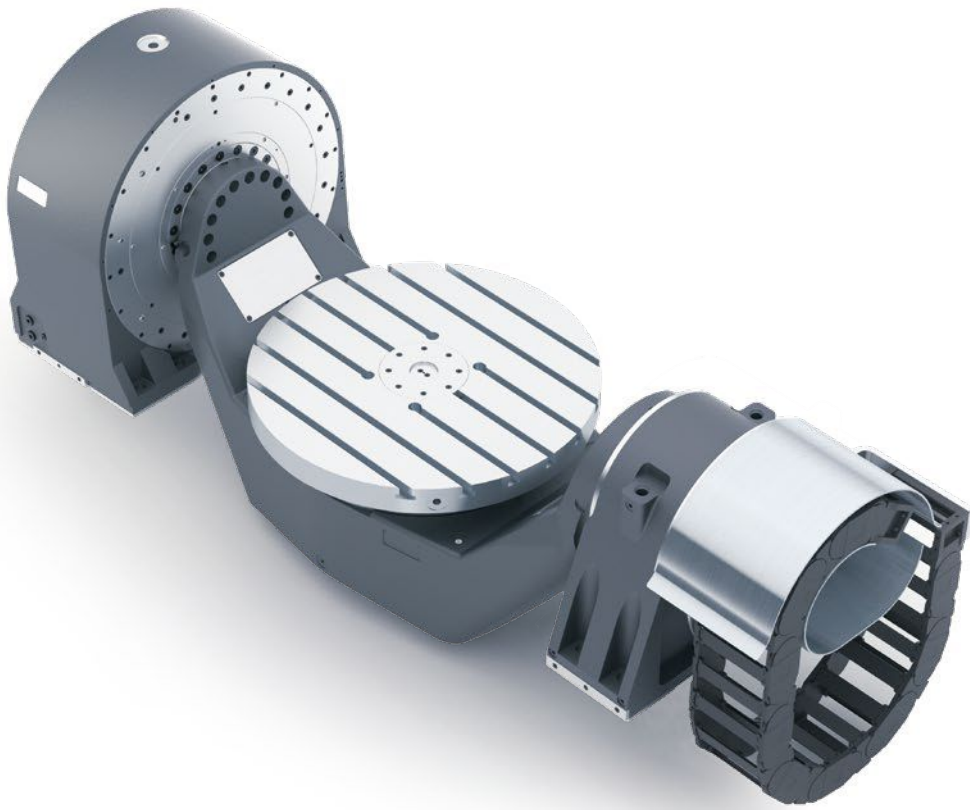

### Modular extensions available

#### A-axis

- + Pneumatic clamping
- + Leakage monitoring
- + Pressure monitoring
- + Cable carrier
- + Measuring system  
with enhanced accuracy for all  
standard control systems

#### C-axis

- + High-speed rotary  
(maximum speed: 1,200 rpm)
- + Pneumatic clamping
- + Leakage monitoring
- + Pressure monitoring
- + 4 and 8 channel rotary union
- + Pallet clamping system
- + Measuring system  
with enhanced accuracy for all  
standard control systems

# MEDIUM 2AT

## A-axis (tilting axis)

- Torque S1: 2 x 1,850 Nm
- Maximum torque: 2 x 3,700 Nm
- Maximum speed: 100 rpm
- Clamping: hydraulic / pneumatic table
- Clamping torque: 2 x 4,000 Nm
- Tilting angle:  $\pm 120^\circ$
- Measuring system: absolute
- Accuracy of measuring system:  $\pm 5''$

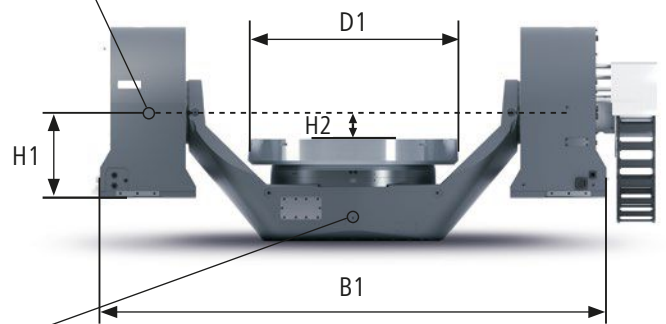

## C-axis (turning axis)

- Torque S1: 1,850 Nm
- Maximum torque: 3,700 Nm
- Maximum speed: 100 rpm
- Clamping: hydraulic / pneumatic table
- Clamping torque: 4,000 Nm
- Measuring system: absolute
- Accuracy of measuring system:  $\pm 5''$

### Dimensions (mm)

Table plate diameter	D1	630 - 800
Distance A-axis to table surface	H2	100
Total width	B1	1,992
Height of A-axis to mounting surface	H1	325
Workpiece - maximum $\varnothing$	mm	1,000
Maximum workpiece height	mm	500
Maximum workpiece weight	kg	1,200
Total weight	kg	2,150

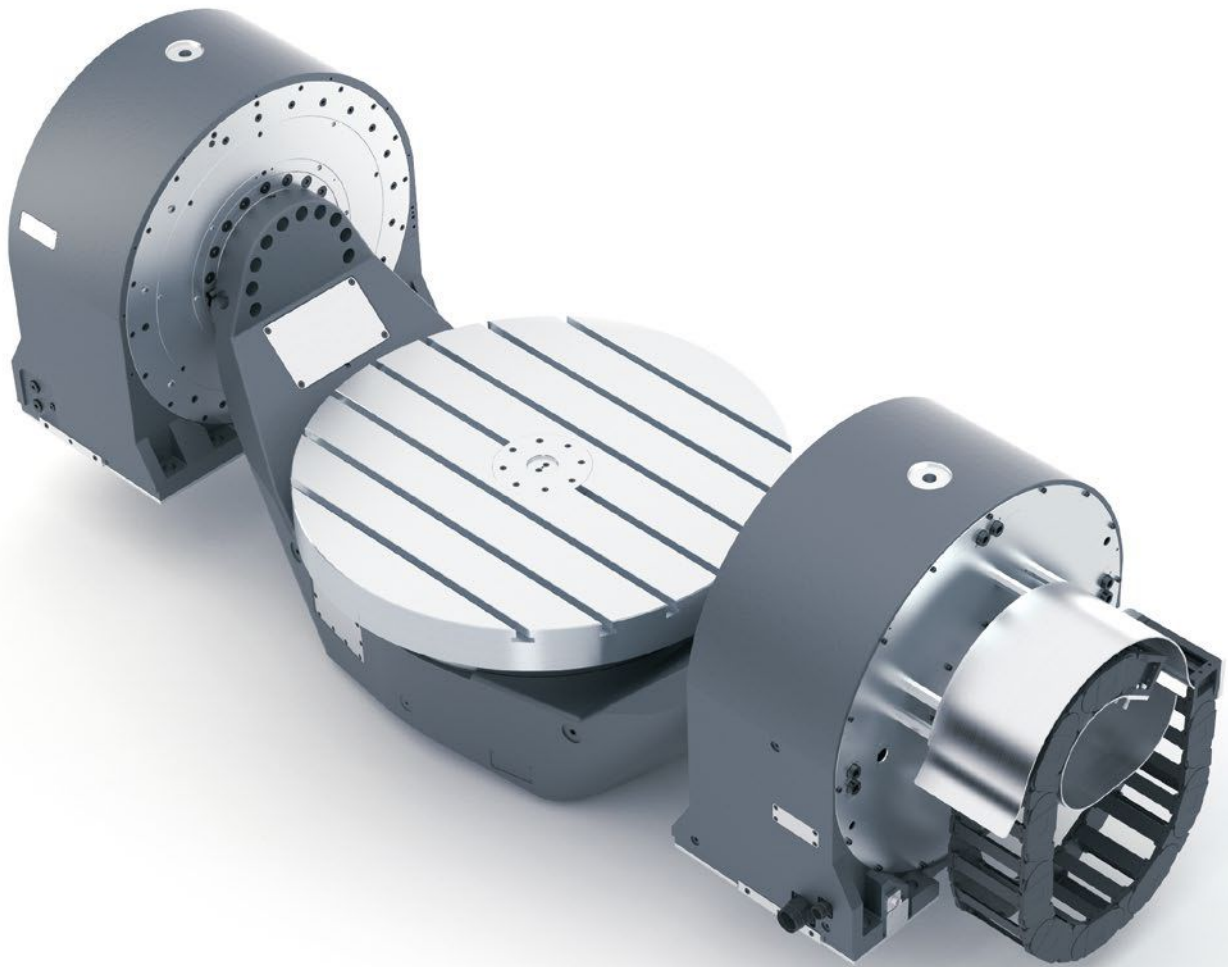

### Modular extensions available

#### A-axis

- + **Pneumatic clamping**
- + **Leakage monitoring**
- + **Pressure monitoring**
- + **Cable carrier**
- + **Measuring system**  
with enhanced accuracy for all  
standard control systems

#### C-axis

- + **High-speed rotary**  
(maximum speed: 1,000 rpm)
- + **Pneumatic clamping**
- + **Leakage monitoring**
- + **Pressure monitoring**
- + **4 and 8 channel rotary union**
- + **Pallet clamping system**
- + **Measuring system**  
with enhanced accuracy for all  
standard control systems



# COOLMOTION

## KESSLER COOLMOTION®

### COOLMOTION® for rotary tilt tables

- achieves a **very high torque density**
- facilitates a **compact design**
- **optimizes simultaneous machining**
- provides **maximum standstill torque**
- ensures **minimum heat input** in the machine structure

KESSLER is the innovation engine behind state-of-the-art direct drive technology and is renowned for powerful and energy-efficient motors with high torque density and top reliability even in high-demand applications. Practically-based simulations and individual customer calculations are a prerequisite for the development excellence of KESSLER motors.

The inverter-optimized COOLMOTION® motors are recognized for their low-loss design and enhanced heat dissipation. Innovative modifications of the motor components have enabled us to reduce the rotor and stator losses by 25%. Special construction measures have resulted in significantly enhanced heat dissipation.

The COOLMOTION® technology optimizes efficiency to a maximum.

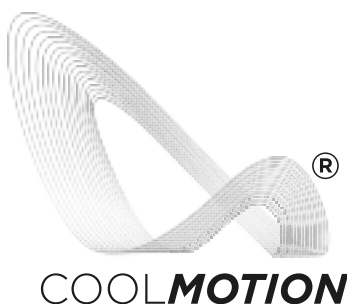

## Table *line* specials

KESSLER, a global table manufacturer, not only provides standard products but also customized special solutions



### Multi-axis rotary tilt tables

for simultaneous machining in multi-spindle machines



### Highly dynamic positioning tables

for up to 1,000 positioning cycles per minute



### 45° tables

high-compact design, optimal for use in machines with little available space

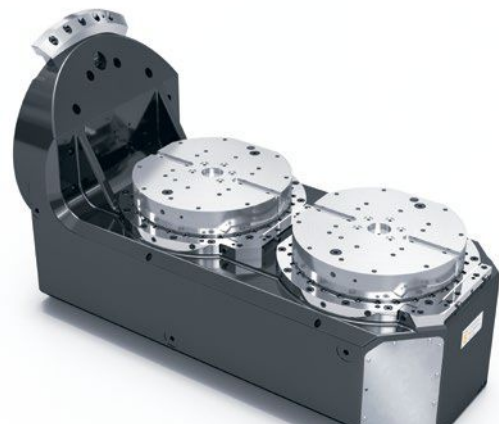

### One-arm rotary tilt tables

compact design for simple table loading and good access during the machining process

# Operating Worldwide for our Customers

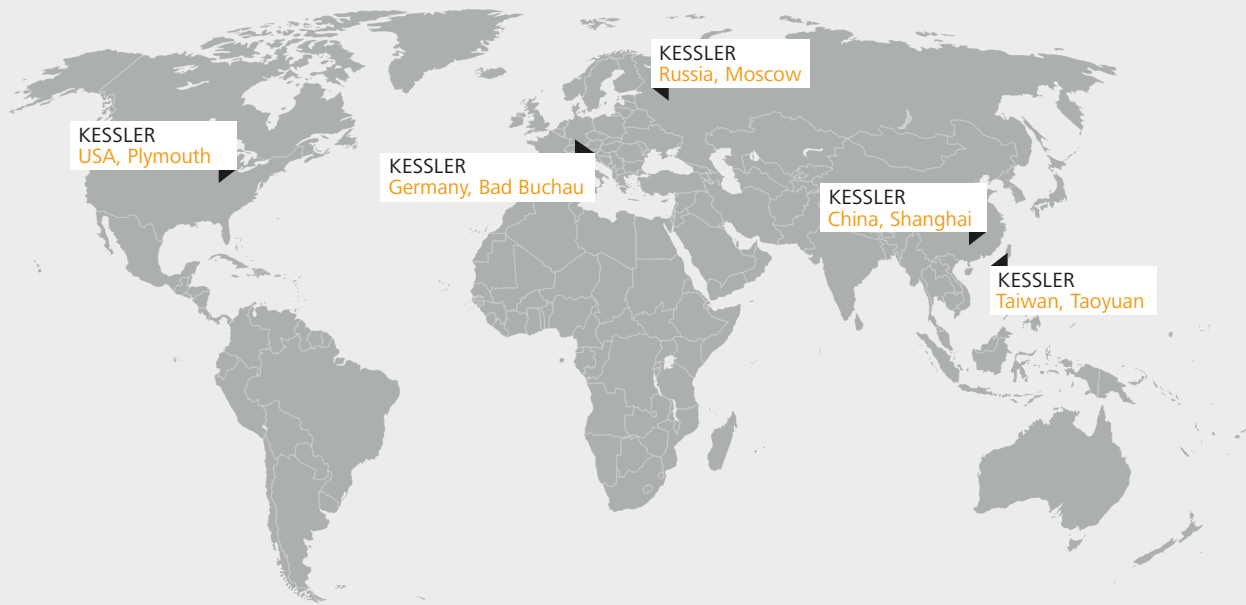

**KESSLER**  
USA, Plymouth

**KESSLER**  
Germany, Bad Buchau

**KESSLER**  
Russia, Moscow

**KESSLER**  
China, Shanghai

**KESSLER**  
Taiwan, Taoyuan

## Germany

**Franz Kessler GmbH**  
Franz-Kessler-Straße 2  
88422 Bad Buchau, Germany  
Tel.: +49 7582 809 - 0  
Fax: +49 7582 809 - 170  
E-Mail: [info@kessler-group.biz](mailto:info@kessler-group.biz)

**KESSLER energy GmbH**  
Franz-Kessler-Straße 2  
88422 Bad Buchau, Germany  
Tel.: +49 7582 809 - 0  
Fax: +49 7582 809 - 170  
E-Mail: [info.energy@kessler-group.biz](mailto:info.energy@kessler-group.biz)

## USA

**KESSLER USA Inc.**  
44099 Plymouth Oaks Blvd.  
Plymouth, MI 48170, USA  
Tel.: +1 734 404 0152  
Fax: +1 734 404 0153  
E-Mail: [info.usa@kessler-group.biz](mailto:info.usa@kessler-group.biz)

## Taiwan

**KESSLER Taiwan Co., Ltd.**  
2F, No.315, Sec 1  
Minsheng N. Rd  
Guishan Township  
Taoyuan County 333  
Taiwan (R.O.C.)  
Tel.: +88 63 326 2256  
Fax: +88 63 355 5014  
E-Mail: [info.tw@kessler-group.biz](mailto:info.tw@kessler-group.biz)

## China

**KESSLER (Shanghai)  
Spindle Service Co., Ltd.**  
Rm. 201 Building #12  
No.318 Yuanshan Rd  
Minhang District  
201108 Shanghai, China  
Tel.: +86 21 6489 7034  
Fax: +86 21 6489 7134  
E-Mail: [info.cn@kessler-group.biz](mailto:info.cn@kessler-group.biz)

## Russia

**KESSLER East Ltd.**  
Dorogobuzhskaja str., 14, bld. 6  
121354, Moscow, Russia  
Tel.: +7 495 204 2450  
E-Mail: [info.ru@kessler-group.biz](mailto:info.ru@kessler-group.biz)

[www.precise-rotation.ru](http://www.precise-rotation.ru)